

## 1 Knowing the Product

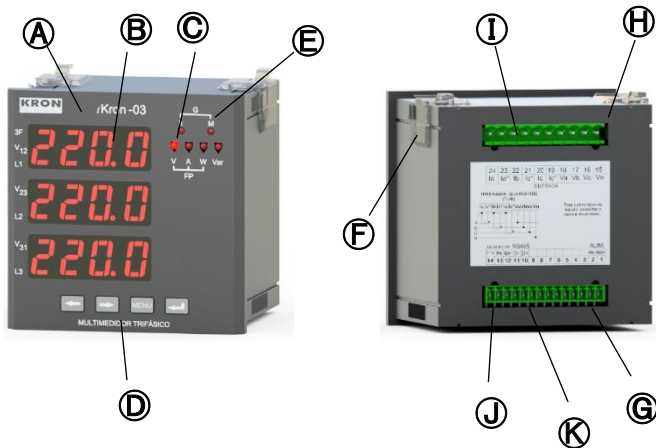

<b>(A)</b>	iKron 03	<b>(G)</b>	Power Supply Input
<b>(B)</b>	LED display Three rows for parameter checking (measurements and configurations)	<b>(H)</b>	Voltage Input
<b>(C)</b>	Indicative LEDs Type of parameter currently showed in the display	<b>(I)</b>	Current Input
<b>(D)</b>	Navigation keys	<b>(J)</b>	Pulse Output
<b>(E)</b>	Indicative LEDs Multiplicative factors (k and M)	<b>(K)</b>	RS-485 Output
<b>(F)</b>	Side locks		

## 2 Installing the product

Accomodate the meter on the panel cutout and fasten it using the side locks **(F)**. Panel's cutout dimensions must be 92x92mm.

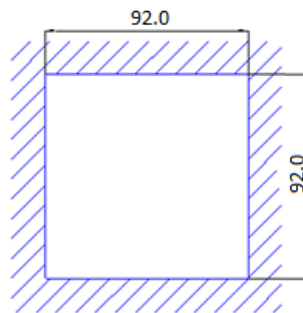

## 3 Power Supply Connection

Power Supply signal must be applied to the **(G)** terminal block. iKron-03's power supply working range is 85...265Vac / 100...350Vdc (universal source).

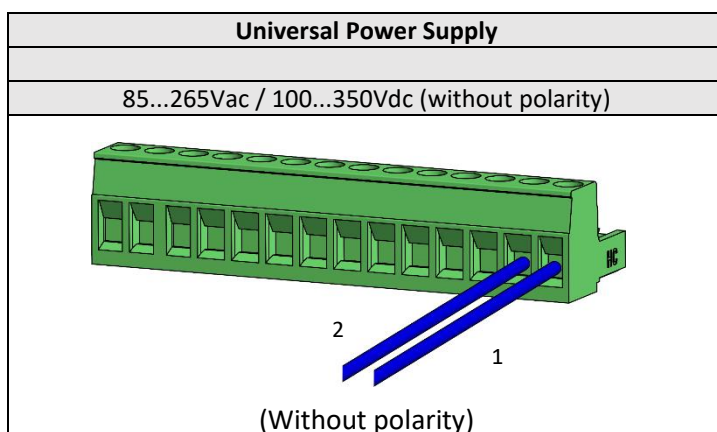

### ATTENTION

Pay extreme attention to the type of auxiliary power supply of your meter.

Incorrect cabling connection or applying a voltage signal above the specified limits can damage it severely.

## 4 Voltage Input Connections

Connect phases and neutral references to the **(H)** inputs, using the order described below:

Terminal Description	Signal to be Connected
18 – Va	'Phase' R
17 – Vb	'Phase' S
16 – Vc	'Phase' T
15 – N	Neutro
<b>Measurement Range: 20 to 500Vac Ph-Ph</b> <b>11,54 to 288,67 Vac Ph-N</b>	

## 5 Current Input Connections

Connect phase references to the **(I)** inputs, using the order described below:

Terminal Description	Signal to be Connected
23 – Ia*	CT's S1 - Phase 'R'
24 – Ia	CT's S2 - Phase 'R'
21 – Ib*	CT's S1 - Phase 'S'
22 – Ib	CT's S2 - Phase 'S'
19 – Ic*	CT's S1 - Phase 'T'
20 – Ic	CT's S2 - Phase 'T'
<b>Measurement Range: 20mA to 5Aac</b> <b>(Continuous Overload: up to 6Aac)</b>	

## 6 Accessing Operation Modes

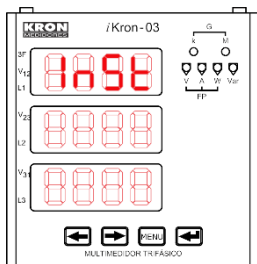

**Instantaneous Measurements:** checking of V, A, W, VAR, VA, PF and Hz values. To access this mode, press the **(MENU)** key until the **Inst** message appears in the display. To navigate through menus use **(←)** or **(→)** keys.

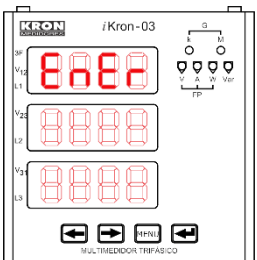

**Energy Measurements:** checking of kWh+, kWh-, kVARh+, kVARh-, kW and kVA values. To access this mode, press the **(MENU)** key until the **Ener** message appears in the display. To navigate through menus use **(←)** or **(→)** keys.

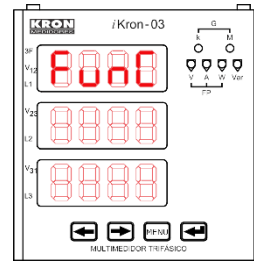

**Function (Configurations):** configuration of constants for PT and CT, connection diagrams, integration time (demand), communication parameters and reset command (energies and demands). To access this mode, hold the **(MENU)** key for three seconds.

## 7 Configuring the Product

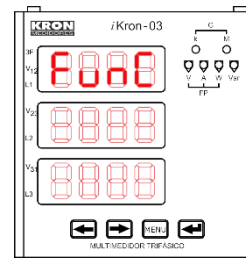

The first step is to access Function mode, by holding the **(MENU)** until the message **FunC** appears in L1. Then, to navigate through menus use **(←)** or **(→)** keys. To enter a specific menu, use the **(↵)** key.

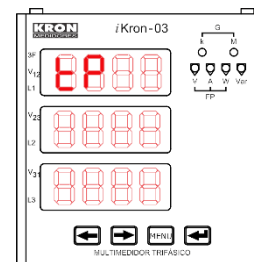

**PT Configuration:** Definition of Potential Transformer ratio.

Example: 440/220V, PT= 0002.00.

Use **(↵)** key to navigate through the digits and **(←)** or **(→)** to increment or decrement the value of the active digit. If no PT is used, PT ratio must

be 0001.00

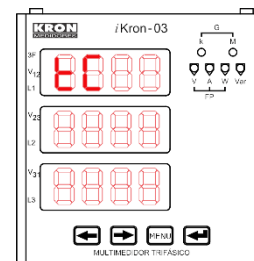

**CT Configuration:** Definition of Current Transformer ratio.

Example: 500/5A, CT = 0100.00.

Use **(↵)** key to navigate through the digits and **(←)** or **(→)** to increment or decrement the value of the active digit. If no CT is used, CT ratio must

be 0001.00

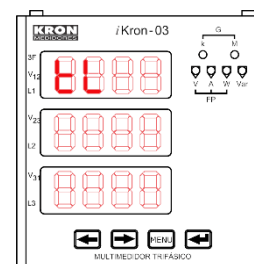

**CD Configuration:** Definition of Connection Diagram, according to the circuit measured.

Use **(↵)** key to navigate through the digits and **(←)** or **(→)** to increment or decrement the value of the active digit. Please refer to the "Connection

Diagrams" table for checking the available CD options.

**To confirm a configured value, press **(↵)** until all digits stop flashing, only the LEDs 'k' and 'M' will be blinking in this situation.**

## Connection Diagram Example: CD-00

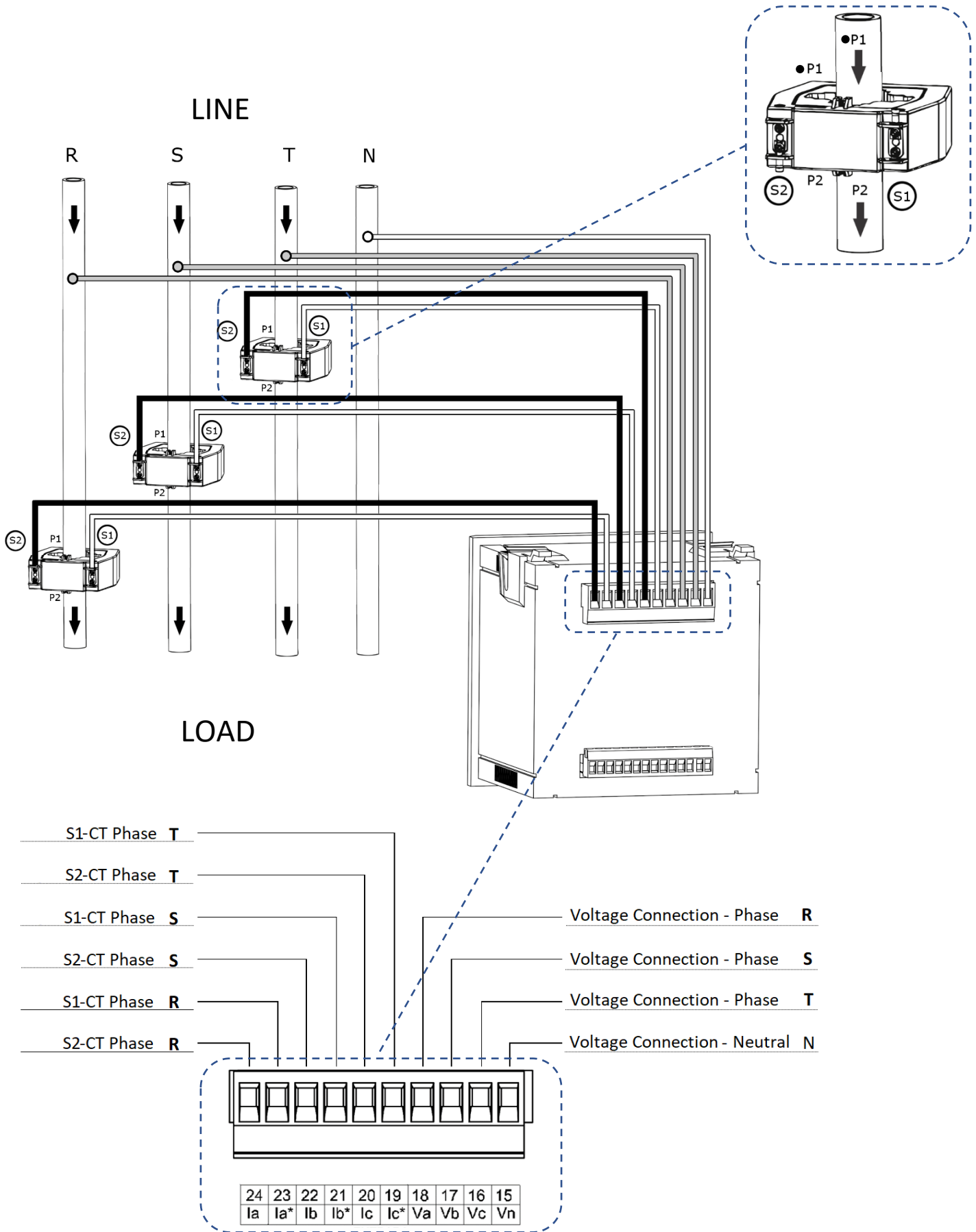

## Connection Diagrams (CD - TL configuration)

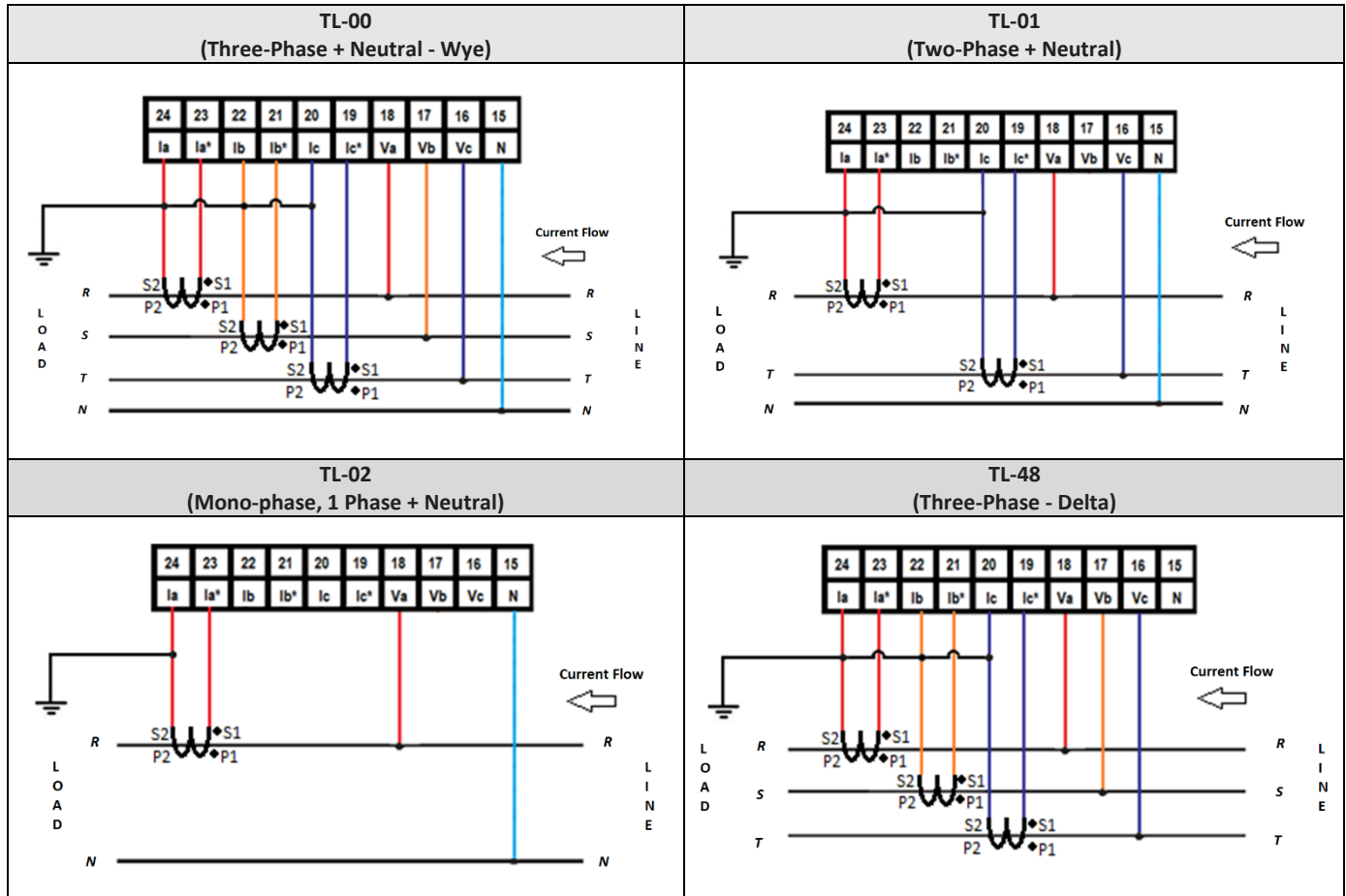

## FAQ – Frequently Asked Questions

### a. The iKron 03 doesn't turn on

Check if the connection to the terminal block **Ⓒ** was made as stated in step **3** and also if the voltage magnitude applied is within the working range for meter's power supply.

### b. Measurement values seem incorrect

Check if voltage and current connections are corresponding to each other, i.e., each meter's channel with the same reference indication - Example: (Va, Ia\* - Ia) - must receive signals from the same phase, as stated in steps **4** and **5**. Also check if the polarity of CTs is correct (Correct Installing, Primary side: (LINE) P1 → P2 (LOAD) | Secondary side, S1 connected to Ix\* → S2 connected to Ix). Also verify if PT, CT and CD configurations are correct.

### c. Which parameter should be read to check energy consumption?

To read energy consumption info, the user must verify the Positive Active Energy parameter (EA). This parameter is the first that appears when Energy Measurements mode is accessed. "EA" is a cumulative value, so, to obtain the energy consumption during a period of time, a prior reading must be subtracted from the current value.

**THIS IS A QUICK USER GUIDE, WITH ESSENTIAL INFO FOR CONFIGURING AND INITIAL OPERATION OF THE METER. FURTHER DETAILS CAN BE CHECKED IN THE PRODUCT'S USER MANUAL, ALSO AVAILABLE IN KRON'S WEBSITE: [www.kron.com.br](http://www.kron.com.br).**